

FT10MHNR FT10MVNR

650 nm DC-10 MBd RedLink® Fiber Optic Transmitter

Data Sheet



DESCRIPTION

The Firecomms DC to 10 MBd RedLink® transmitter is based on the highly reliable Firecomms designed Resonant Cavity Light Emitting Diode (RCLED) technology.

It is housed in a non-conducting plastic RedLink® connector. The 10 MBd transmitter is gray in colour. The housings are compatible with the Versatile Link style fiber plug and are optimized for use with Plastic Optic Fiber (POF) and Plastic Clad Silica (PCS).

The transmitter can be driven from TTL type logic drivers. It operates over the industrial temperature range of -40 °C to +85 °C, supporting many industrial applications where reliable command and control response is required in electrically harsh environments.

The transmitter uses a large-current aperture (150 µm diameter) red (650 nm) eye-safe RCLED based on InGaP/InGaAlP/GaAs technology. It operates over a wide range of drive current that can be adjusted using a serial resistor to minimize current consumption for a given link distance.

AVAILABLE OPTIONS

Table 1
ORDERING INFORMATION / PART NUMBERS

10 MBd Horizontal Package Non-Inverting, TTL	FT10MHNR
10 MBd Vertical Package Non-Inverting, TTL	FT10MVNR

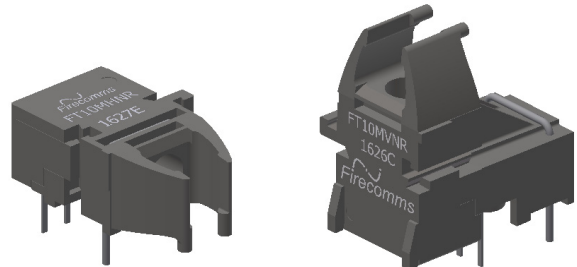

FEATURES

- Ideal for use with POF
- Optimized for data transmission from DC to 10 MBd
- Industrial temperature range -40 °C to +85 °C
- RoHS and UL compliant
- Flame retardant (UL 94 V-0) connector housings
- RCLED transmitter with visible red light (650 nm wavelength)
- Low pulse width distortion
- Compatible with Versatile Link cables and connectors

APPLICATIONS

Table 2
APPLICATIONS

Application	Automation and Industrial Control, Low-Speed Serial Communications, Voltage Isolation
Standard	Serial RS232, RS485, CAN Bus, Modbus, Profibus, Sercos
Distance	50 meters Step Index (SI) POF ^[1] 300 meters with 200 µm PCS fiber ^[1]
Speed	DC to 10 MBd

Note: 1. Depending on the installation conditions

SPECIFICATIONS

Table 3
TRANSMITTER PIN DESCRIPTION

Pin	Name	Symbol
1	RCLED ANODE	TD +
2	RCLED CATHODE	TD -
3	Not Connected	N.C.
4	Not Connected	N.C.
5	Retaining Pin	Gnd
8	Retaining Pin	Gnd

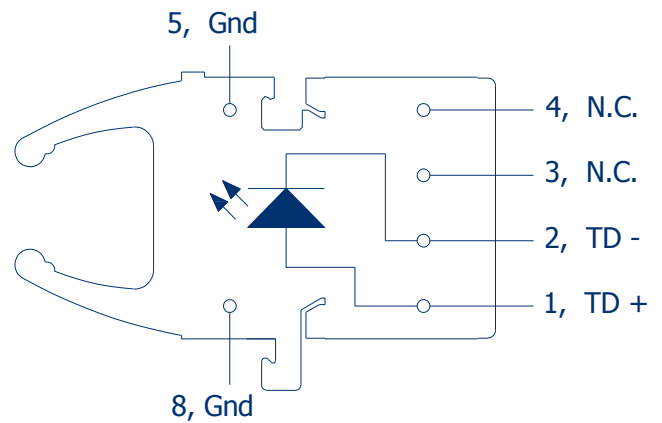
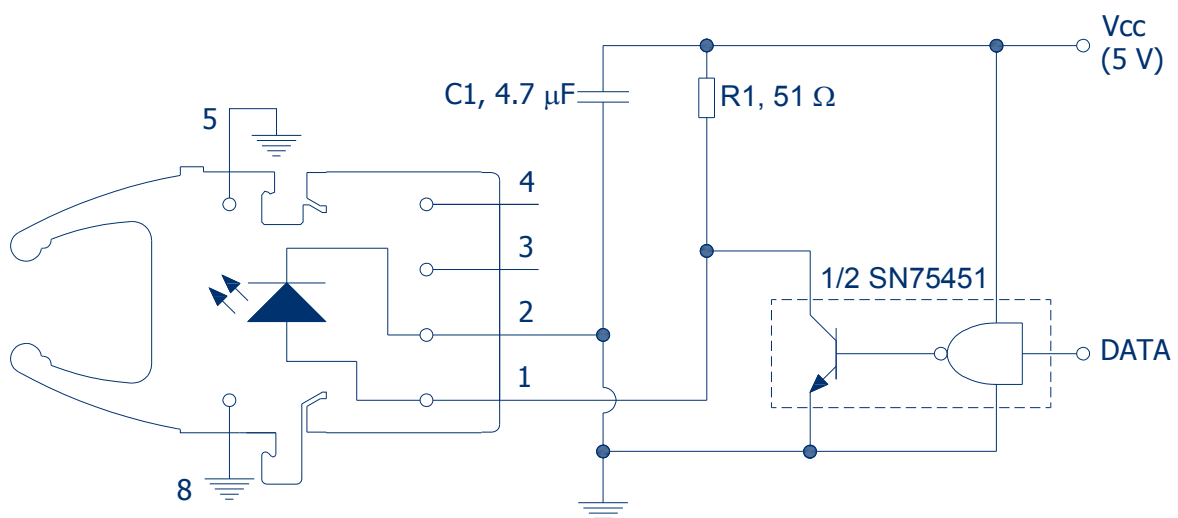

FIGURE 1
Transmitter pin-out, top view

Table 4
REGULATORY COMPLIANCE

Parameter	Symbol	Standard	Level
Electrostatic Discharge, Human Body Model (contact ESD)	HBM	Mil-STD-883	Level 2 (4 kV)
Radiated Emissions Immunity	Vm^{-1}	IEC 61000-4-3	15 Vm^{-1}
UL Certification	UL	94 V-0	Files No. E362227
Storage Compliance	MSL	J-STD-020E	2a (4-week floor life)
Restriction of Hazardous Substances Directive	RoHS	Directive 2011/65/EU	Certified compliant
Eye Safety		IEC 60825-1	LED Class 1

RECOMMENDED APPLICATION CIRCUIT



NOTE: $R1 = 51 \Omega$, then I_F drive current is approximately 60 mA. To reduce drive current, select a higher $R1$ value

FIGURE 2
Recommended transmitter application circuit. See note 7 Table 6

SPECIFICATIONS

Table 5
ABSOLUTE MAXIMUM RATINGS

These are the absolute maximum ratings at or beyond which the part can be expected to be damaged

Notes:

1. 260 °C for 10 seconds, one time only, at least 2.2 mm away from lead root
2. When peak forward current exceeds 60 mA then the duty cycle must maintain a pulse width (PW) less than 1 μ s and average forward current less than or equal to 60 mA. [60 mA \leq I_{FPK} \leq 90 mA \leftrightarrow I_{FAVG} \leq 60 mA AND PW \leq 1 μ s]

Parameter	Symbol	Minimum	Maximum	Unit
Storage Temperature	T _{stg}	-40	+85	°C
Operating Temperature	T _{op}	-40	+85	°C
Soldering Temperature ^[1]	T _{slid}		+260 ^[1]	°C
TX Reverse Input Voltage	V _{BR}		-10	V
TX Forward Input Current ^[2]	I _{FDC}		80	mA
TX Peak Forward Input Current ^[2]	I _{FPK}		1000	mA
Average Forward Input Current ^[2]	I _{FAVG}		60	mA

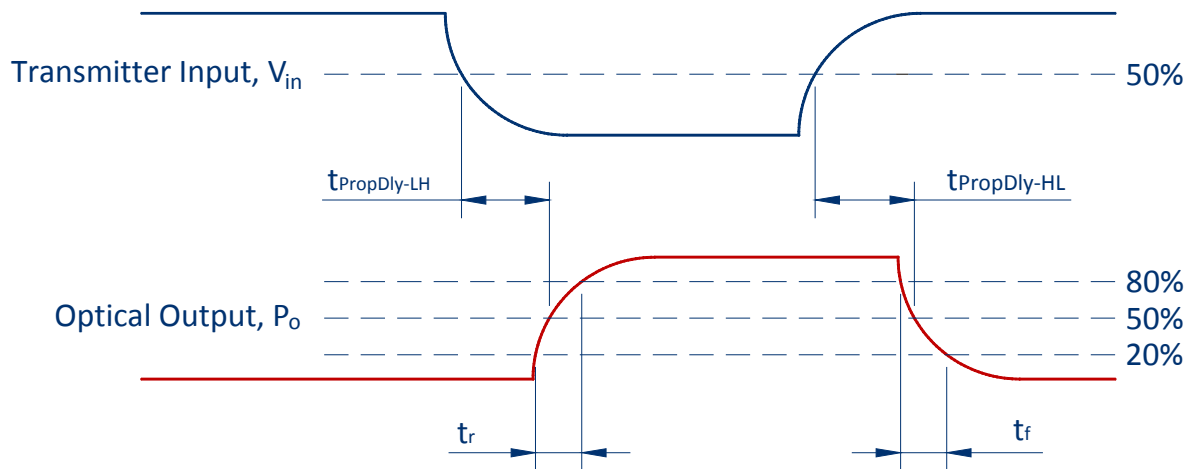

FIGURE 3
Transmitter Propagation Delay and rise/fall time definitions as per application circuit of Figure 2

SPECIFICATIONS

Table 6
TRANSMITTER ELECTRICAL AND OPTICAL CHARACTERISTICS

Parameter	Symbol	Min	Typical	Max	Unit	Test Condition
<i>Test Conditions:</i>						
1. Test data was validated over the full temperature range of -40 °C to +85 °C, and over the full drive current range						
2. Optical power for POF is measured when coupled into 0.5 m of a 1 mm diameter 0.5 NA POF and a large area detector						
3. Optical power for PCS is measured when coupled into 0.5 m of a 200 μm diameter PCS and a large area detector						
4. As measured in the given application circuit (inverting) shown in Figure 2 over 50 cm of 0.5 NA POF						
5. Emission Wavelength (centroid) $\lambda_c = \sum i P_i \lambda_i / \sum i P_i$. (Ref: EIA/TIA std. FOTP-127/6.1, 1991)						
6. Spectral Width Root Mean Squared (RMS) $\lambda_{RMS} = (\sum i P_i (\lambda_c - \lambda_i)^2 / \sum i P_i)^{1/2}$ (ref: EIA/TIA std. FOTP-127/6.3, 1991)						
7. Pins 5 and 8 are used for mounting and retaining purposes only. Connect to ground						
Output Optical Power	P_o	-7.2	-3.5	+1.3	dBm	1 mm POF $I_{FDC} = 60$ mA
		-16.8	-9.0	-0.7	dBm	1 mm POF $I_{FDC} = 20$ mA
		-17.3	-12.5	-7.2	dBm	200 μm PCS $I_{FDC} = 60$ mA
Emission Wavelength (centroid) ^[4]	λ_c	635	650	665	nm	$I_{FDC} = 30$ mA
Spectral Width (RMS) ^[6]	λ_{RMS}		11	16	nm	$I_{FDC} = 30$ mA
Forward Voltage	V_F	1.8	2.1	2.65	V	$I_{FDC} = 60$ mA
Forward Voltage Temperature Coefficient	$\Delta V_F / \Delta T$		-3.3		mV/°C	$I_{FDC} = 60$ mA
Reverse Input Breakdown Voltage	V_{BR}	10			V	$I_{FDC} = -1$ μA
Diode Capacitance	C_o		11		pF	V = 0 V
TX Numerical Aperture	NA		0.5			$I_{FDC} = 60$ mA
Data Rate		DC		10	MBd	Min UI = 100 ns Max f = 5 MHz
Optical Rise Time (20 % - 80 %)	t_r		6	9	ns	$I_{FAVG} = 30$ mA ^[4] Fig 3
Optical Fall Time (80 % - 20 %)	t_f		8	11	ns	$I_{FAVG} = 30$ mA ^[4] Fig 3
Propagation Delay Low-to-High (ELEC – OPTO)	$t_{PropDly_LH}$	20	23	30	ns	$I_{FAVG} = 30$ mA ^[4] Fig 3
Propagation Delay High-to-Low (ELEC – OPTO)	$t_{PropDly_HL}$	18	25	36	ns	$I_{FAVG} = 30$ mA ^[4] Fig 3
Pulse Width Distortion	PWD	-4	2	8	ns	$I_{FAVG} = 30$ mA ^[4] Fig 3

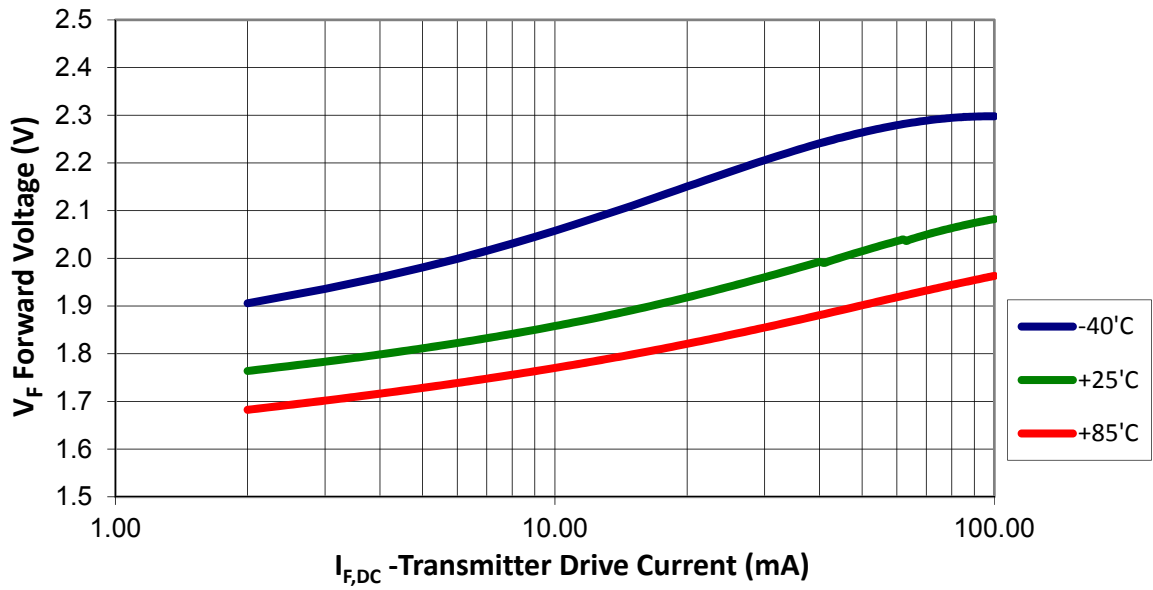

FIGURE 4
Typical forward voltage (V_F) vs. drive current ($I_{F,DC}$).

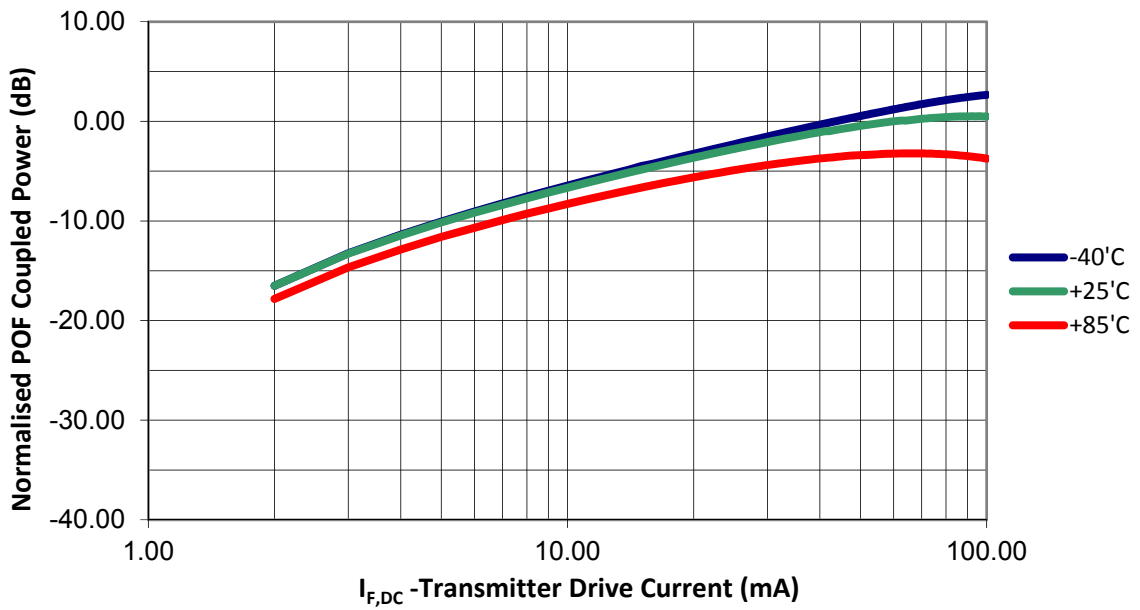

FIGURE 5
Typical normalized optical power vs. drive current.

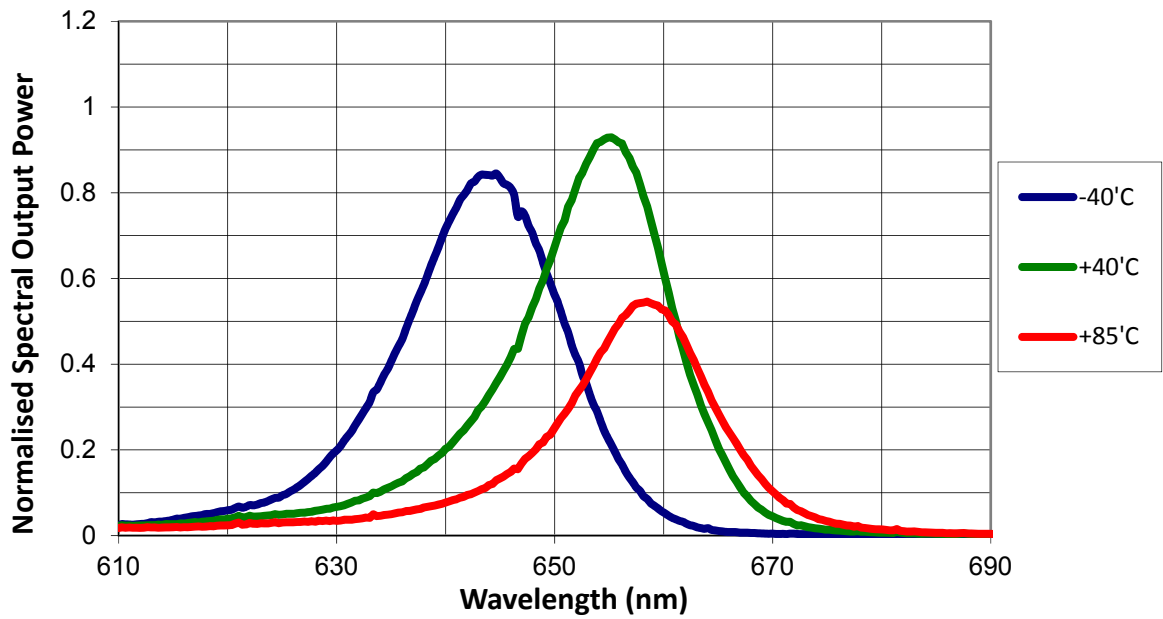

FIGURE 6
Typical normalized optical spectra.

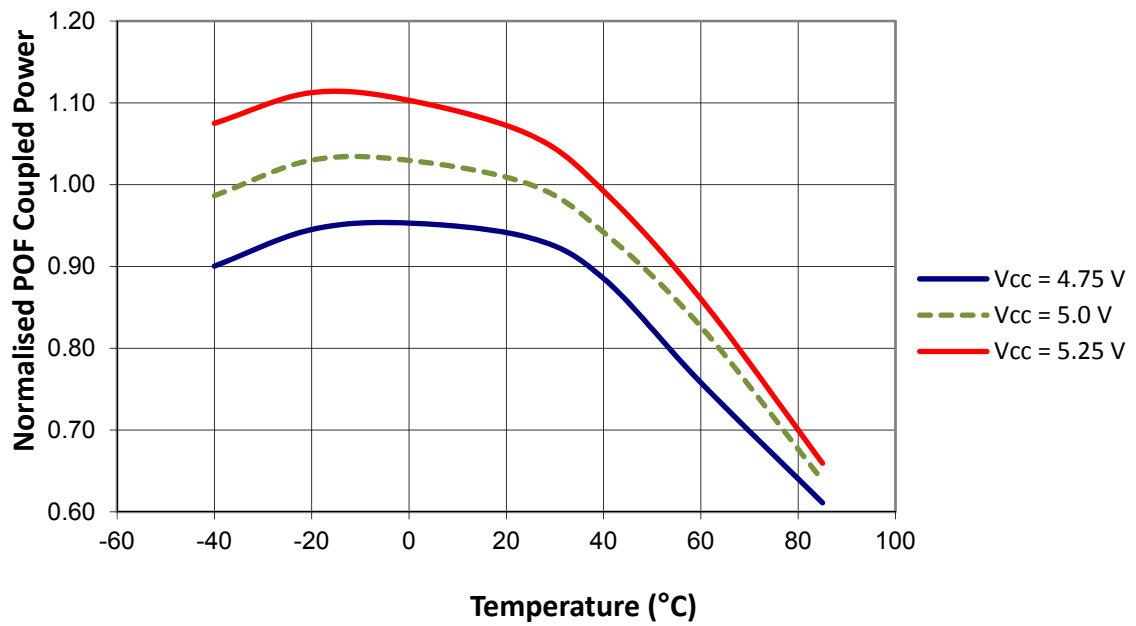

FIGURE 7
Typical normalized optical power vs. temperature (in recommended drive circuit).

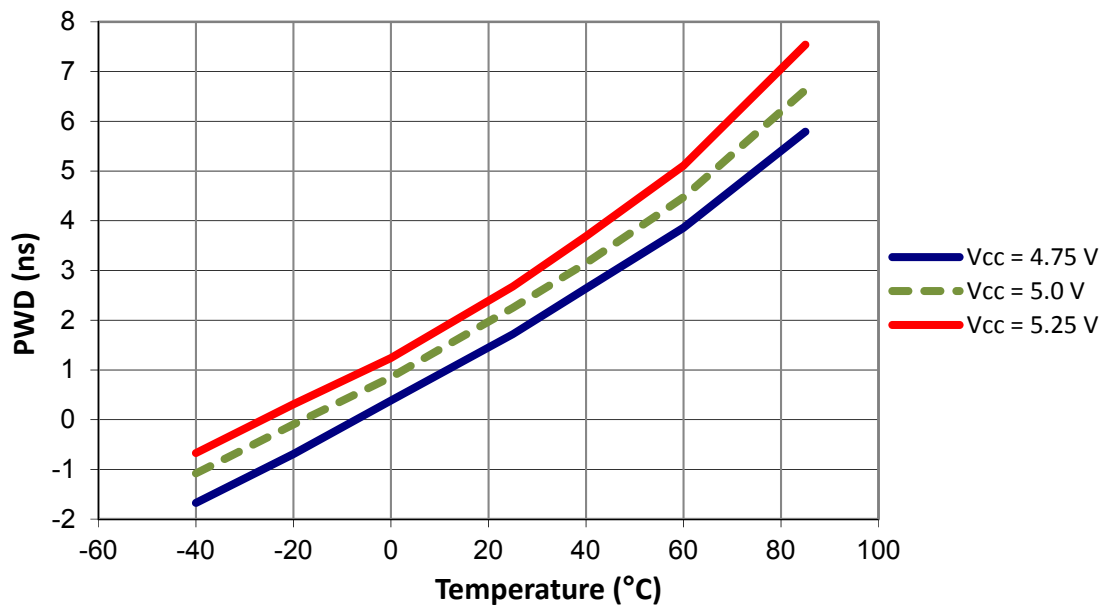

FIGURE 8
Typical optical pulse width distortion vs. temperature and power supply voltage (in recommended drive circuit).

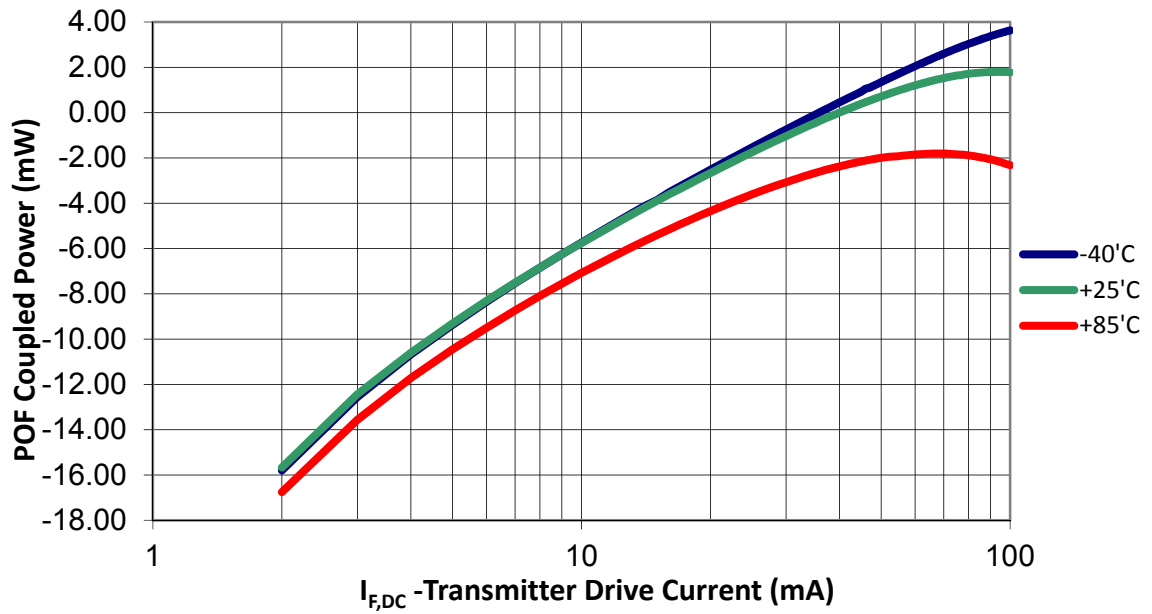

FIGURE 9
Typical POF coupled optical power vs. drive current.

MECHANICAL DATA, HORIZONTAL

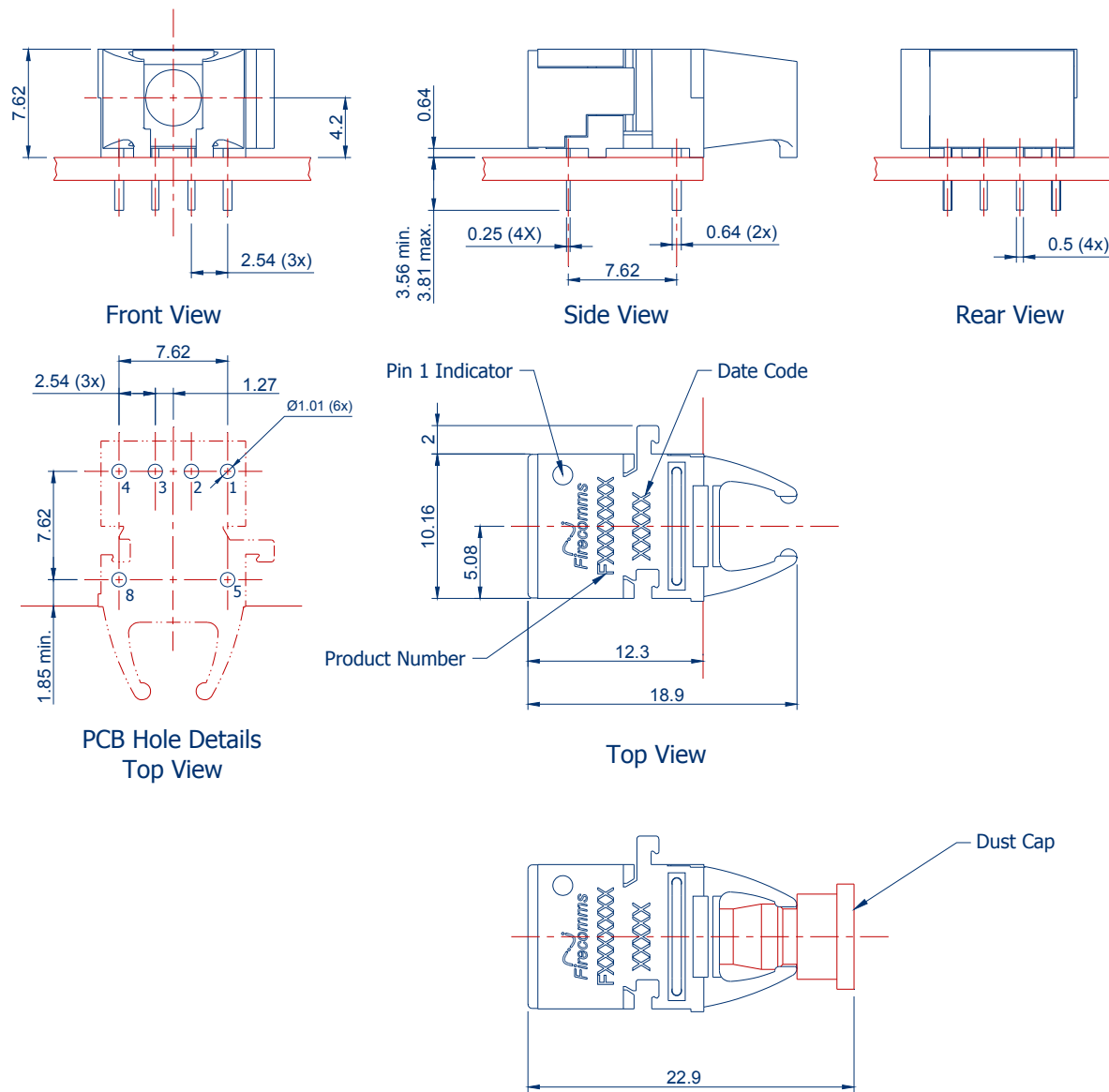

FIGURE 10
Mechanical dimensions of the horizontal connectors and PCB footprint, which is a top view
General dimensional tolerance is ± 0.2 mm

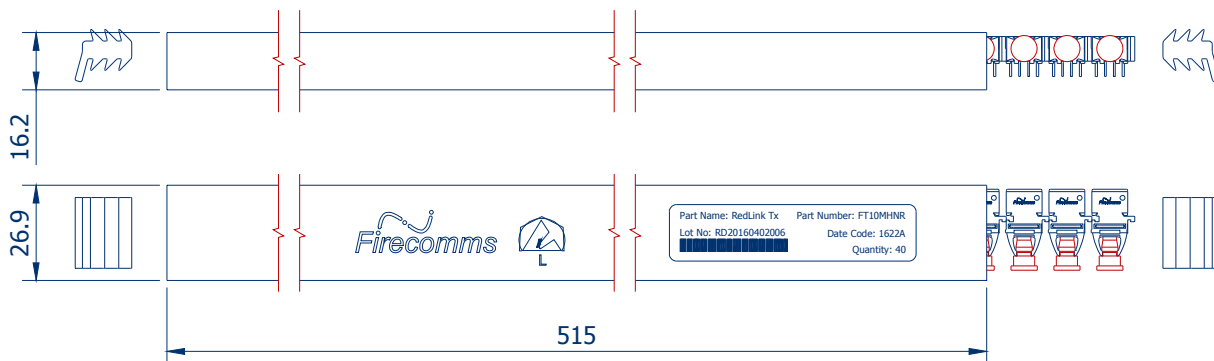

FIGURE 11
Packing tube for Firecomms Horizontal RedLink® Transmitters

MECHANICAL DATA, VERTICAL

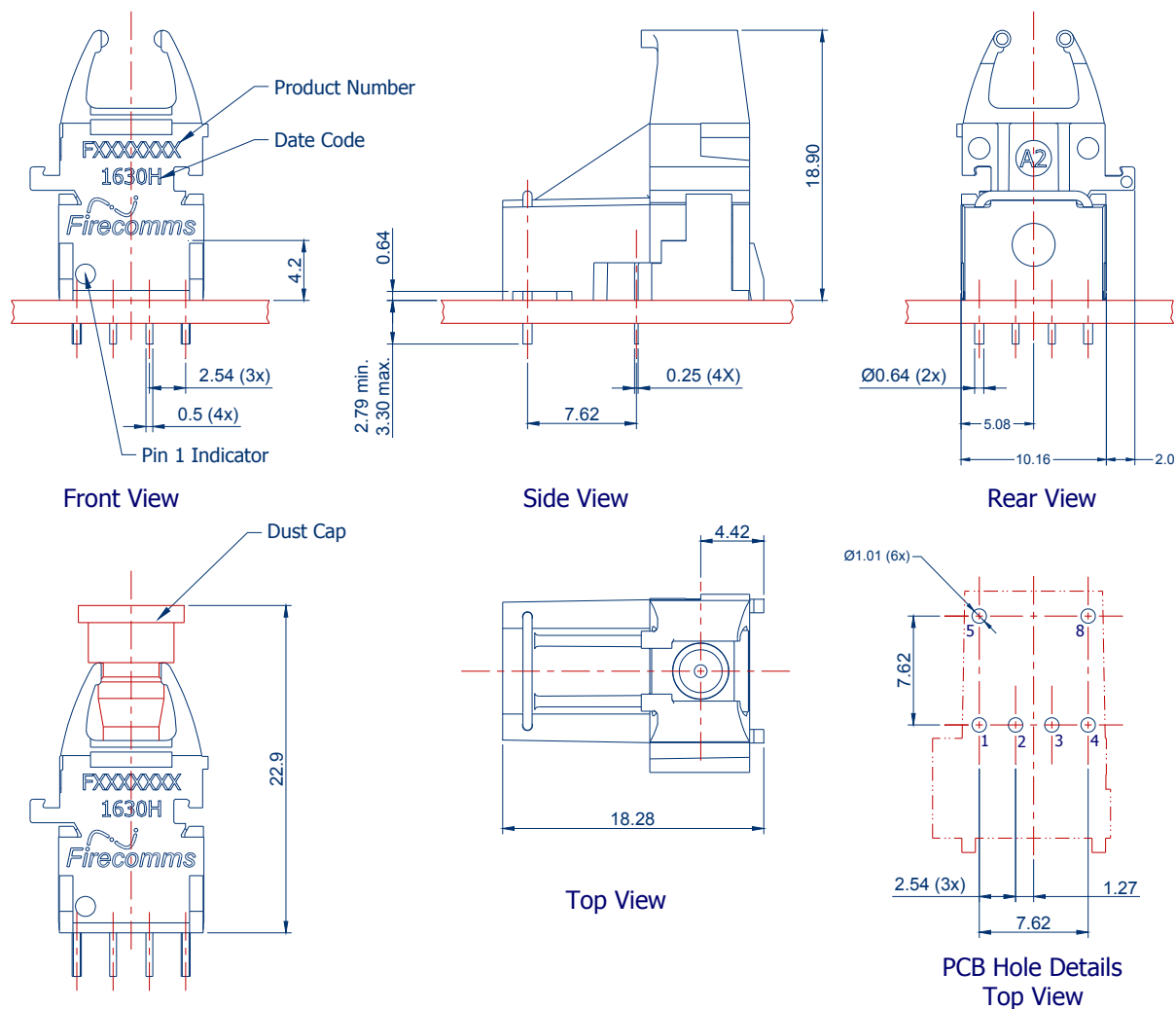

FIGURE 12
Mechanical dimensions of the vertical transmitter connectors and PCB footprint, which is a top view
General dimensional tolerance is ± 0.2 mm

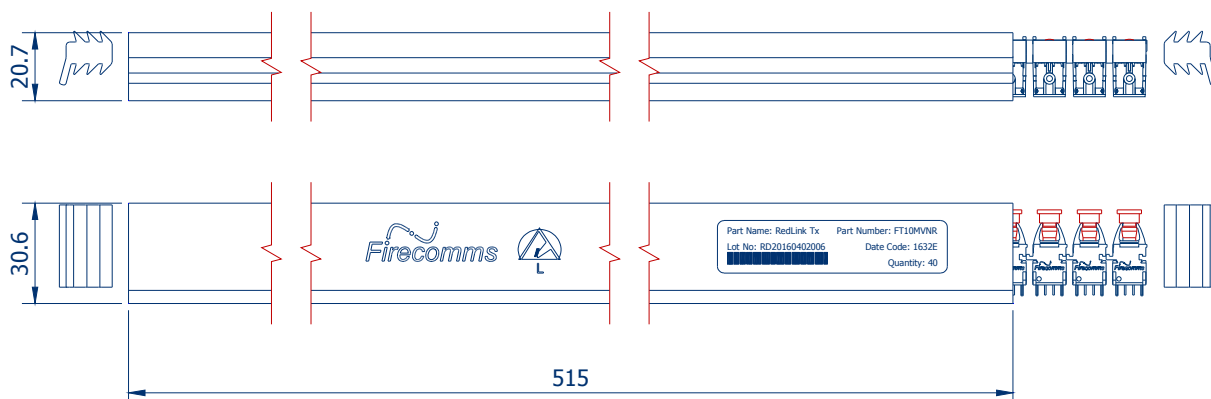

FIGURE 13
Packing tube for Firecomms Vertical RedLink® Transmitters

PART HANDLING

The Firecomms DC-10 MBd 650 nm RedLink® transmitter devices are color coded gray. They are auto-insertable. They are tested for handling in static-controlled assembly processes (HBM). Cleaning, degreasing and post solder washing should be carried out using standard solutions compatible with both plastics and the environment. For example, recommended solutions for degreasing are alcohols (methyl, isopropyl and isobutyl). Acetone, ethyl acetate, phenol or similar solution based products are not permitted.

In the soldering process, non-halogenated water soluble fluxes are recommended. These products are not suitable for use in reflow solder processes (infrared/vapor-phase reflow). The dust plug should remain in place during soldering, washing and drying processes to avoid contamination of the active optical area of each part.

The Moisture Sensitivity Level (MSL) classification of this device is 2a according to JEDEC J-STD-020E. The shelf life of an unopened MBB (Moisture Barrier Bag) is 24 months at < 40 °C and < 90 % R.H. Once the Moisture Barrier Bag is opened the devices can be either

- a) Stored in normal factory conditions < 30 °C and < 60 % R.H. for a maximum of 672 hours (4 Weeks) prior to soldering.
- b) Stored at < 10 % R.H. (Dry Cabinet).

PACKING INFORMATION

Components are packed in PVC anti-static tubes in moisture barrier bags. Bags should be opened only in static-controlled locations, and standard procedures should be followed for handling moisture sensitive components.

Table 7
PACKING INFORMATION

	Horizontal	Vertical
Components per Tube	40	40
Tube Length	515 mm	515 mm
Tube Height	16.2 mm	21.0 mm
Tube Depth	26.9 mm	30.8 mm
Tubes per Bag	5	5
Bags per Inner Carton	1	1
Inner Carton Length	630 mm	630 mm
Inner Carton Width	70 mm	70 mm
Inner Carton Height	105 mm	105 mm
Weight per Inner Carton, Complete	0.77 kg	0.92 kg
Components per Inner Carton	200	200
Inner Cartons per Outer Carton	10	10
Outer Carton Length	650 mm	650 mm
Outer Carton Width	235 mm	235 mm
Outer Carton Height	376 mm	376 mm
Weight per Outer Carton, Complete	8.13 kg	9.60 kg
Components per Outer Carton	2,000	2,000

For the most recent revision or further information please visit www.firecomms.com or contact the company directly at the following address, Firecomms Ltd, 2200 Airport Business Park, Cork, IRELAND. Copyright© 2004-20016 Firecomms. All rights reserved. Firecomms refers to Firecomms Limited and/or its subsidiaries. Firecomms assumes no responsibility for inaccuracies or omissions in the information contained in this document. Specifications are subject to change without notice. No patent rights are granted to any of the circuits described herein.